

# Mobile Interrogation Unit for Passive SAW-Sensors in Long-Term ECG-Monitoring

Thomas Finnberg, Anna Karilainen, Jörg Müller  
Technische Universität Hamburg-Harburg  
Eissendorfer Str. 42, 21073 Hamburg  
Phone: +49 (0)40 42878 4079, Fax: +49 (0)40 42878 2396  
E-mail: [finnberg@tu-harburg.de](mailto:finnberg@tu-harburg.de)

*Abstract*— An interrogation unit for wireless Holter electrocardiogram (ECG) based on passive surface acoustic wave (SAW) sensors is presented. The sensor system is able to simultaneously monitor six small voltages in the millivolt-range. The application of the sensor network is not restricted to ECG measurement, it can be used for other biopotential signals, or industrial applications with only minor changes of the sensor. All Sensors consist of SAW-delay lines with voltage-dependent impedance loading on a reflector interdigital transducer (IDT). Simultaneous monitoring of multiple potentials is realised by time-division-multiplexing of different sensor signals. Pulse radar technique is used to interrogate the sensors.

*Keywords*— SAW-sensor; ECG; wireless; biopotential; measurement; long-term-monitoring;

## I. INTRODUCTION

One of the major challenges of medical technology today is the monitoring of heart disease risk groups. About 300.000 people in Germany suffer a heart attack annually. New monitoring techniques such as the ECG monitor system presented in this paper could decrease this number dramatically.

Monitoring risk groups, e.g. people with recent bypass or pacemaker implementation would enable to take preventive action in a very early stage, thus resulting in a decreased risk of permanent and irreparable damage of the organs, or even death. Long-term recording of ECG is a standard procedure in current cardiac medicine. Common systems are capable of storing the measured heart potential of three ECG channels for a time period of 48 hours.

Furthermore the interrogated data is scanned for attack symptoms. If such an event is recognized an alarm can

be initiated, informing the doctor about the current symptoms.

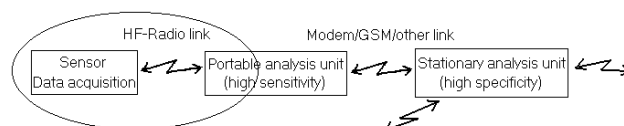

Figure 1 ECG-monitoring system with sensor, portable reader and stationary central analysis unit.

The chest-electrodes of a standard ECG monitoring system are connected via cables to the recording unit, which must be worn on the body during daily activities and sleep. If the cables between the electrodes and the recording unit were replaced by a radio link, the patient comfort would be increased dramatically. All wireless interrogation units presented so far are based on active sensors, meaning that every sensor incorporates its own battery. In the field of ECG long term monitoring where the measurement interval is 1ms to 5ms short and the interrogation time is at least 48 hours long, this leads to problems regarding the current consumption of the sensors. Getting rid of the battery would furthermore lead to less maintenance and a reduced cost factor.

The goal of our project is the development and evaluation of a wireless ECG system totally based on passive SAW-sensors. The whole system is shown in Figure 1. In this paper we focus on the data-acquisition and the RF-part of the interrogation unit. Further information on the SAW-sensor can be found in [1].

## II. SAW SENSORS

A total set of three leads (sensors) is usually required to obtain useful data of the heart function in a standard

ambulatory Holter-monitoring, and 12 leads are used to get the full dataset. Each sensor consists of a SAW delay line, a load circuit, and the electrodes attached to the patient's chest, as illustrated in Figure 2. The sensor effect relies on the variation of impedance in the load circuit, which, next to the electrodes, is contacted to the reflecting IDT on the SAW-device. The impedance relates to the dynamic heart potential through a varactor diode.

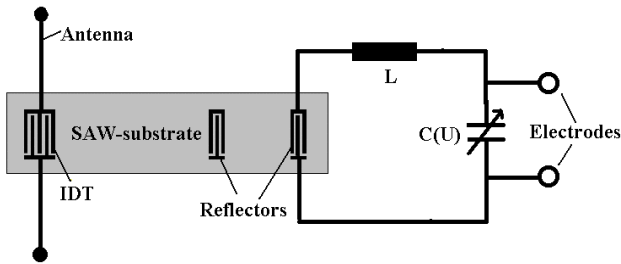

**Figure 2 Design of the heart-potential sensor.**

Pulse radar technique is used to interrogate the sensors. A high frequency impulse is sent out by the interrogation unit, received by the antenna of the sensor, and transformed into an acoustic surface wave. This wave travels across the piezoelectric surface of the SAW, is partially reflected by the reference reflector and finally reaches the IDT connected to the load circuit. The signal reflected at this IDT is modulated in amplitude and phase according to the heart-potential at the instant of measurement. The reflected pulses are then transmitted by the antenna to the interrogation unit. From the received signal the evaluation electronics calculate the desired physical values.

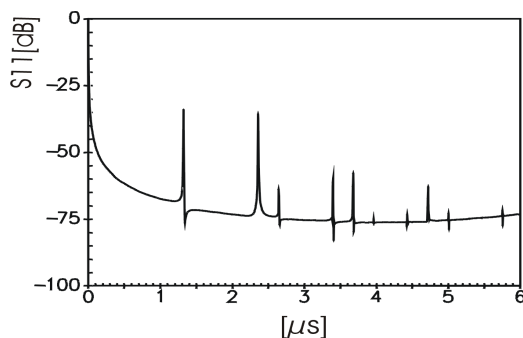

**Figure 3 Sensor response of the first sensor. The first two peaks represent the reflection of reference and measurement IDT.**

To separate the signals from individual sensors, the reflector and the measurement IDT on each sensor are placed on the SAW-chip surface with a fixed increasing offset distance resulting in a time-multiplexed system response. The sensor response of a single SAW-Sensor is shown in Figure 3.

Measuring biopotential signals is a challenging task, because they are very small. An ECG-signal is in the range of a few millivolts and less. The change of impedance of the load circuit is limited by the capacitance ratio of the varactor diode. Close attention must be paid on the high quality-factor of the load circuit. Another feature of measuring heart-potentials is that there are different types of parasitic potentials adding up to the actual ECG-signal, such as an offset potential caused by different polarization of the two electrodes, and motion artefacts. These voltages can be up to tens or hundreds of millivolts. The sensor is fitted to maximum resolution at the desired measurement range by adjusting the quality-factor of the load-circuit.

Compared to other passive sensor architectures, namely the inductive and capacitive coupling, SAW-sensors have a much longer interrogation range of up to 10 m [2]. Furthermore SAWs are reliable and small in size. The sensors used in our application have a surface area of only 2x7 mm.

### III. INTERROGATION UNIT

To interrogate the ECG sensor a high-frequency read impulse is sent out from the evaluation station. The load-circuit on the sensor detunes the signal capacitively. From the received signal the evaluation electronics calculate the desired physical values.

Figure 4 shows the block diagram of the interrogation unit. The radio frequency is derived from a 2.45 GHz voltage controlled oscillator (VCO). Following the VCO is a RF-switch, generating impulses of 100 ns length, which are amplified to 10 dBm and transmitted by the antenna to the SAW-sensors. All sensors within the detection range reflect several bursts, modulated in amplitude and phase, after an initial delay of 1.4 microseconds. The delay prevents spurious echoes from the surroundings from distorting the sensor signals. Another interrogation technique, the frequency modulated continuous wave (FMCW) method, is currently being evaluated for its suitability in the project.

After the antenna has been switched from the transmission to the receive path, the amplified incoming signals are fed to a quadrature demodulator. This demodulation technique results in two orthogonal components, which reflect the phase angle of the

incoming signal referred to the oscillator and the amplitude. The quadrature components are sampled by a fast two channel analog-digital converter and transmitted for further processing to a digital signal processor (DSP).

The DSP separates the sensor responses according to the time latency of the specific sensors. After that, the DSP is able to determine the overall attenuation of the signal path by evaluating the amplitude of the reflector signal. The biopotential value can now be derived by computing the phase and amplitude difference of the sensor IDT and the reflector signal.

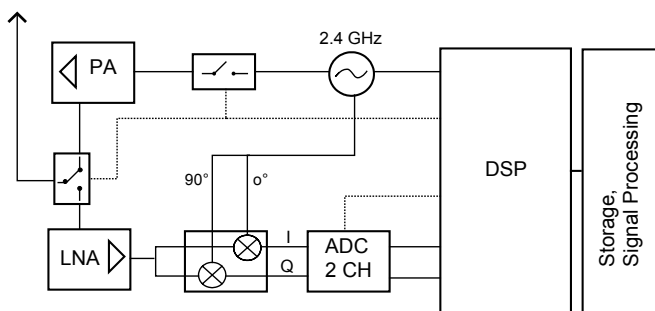

**Figure 4 Block diagram of the interrogation unit**

The acquired data from the ECG-sensors are further processed by another DSP, which is responsible for signal processing and storage of the data. This unit is also capable to detect certain attack symptoms. The two DSPs are connected via a fast I<sup>2</sup>C interface.

In this project two main design issues have to be taken into account. The first is the current consumption of the interrogation unit. Since the device has to be driven from the limited power of a battery, all active components must be chosen according to their suitability for a low power design. Secondly the interrogation unit has to be small in size, making it comfortable for the patient to handle the device. These design issues have to be solved in the further development of the device. For now the main field of interest was the implementation of a running demonstrator.

One crucial design issue is the choice of a suitable operating frequency. Frequency-bands of interest are in particular the ISM Bands at 434 MHz, 869 MHz and 2,45 GHz, which can be used without licensing and charge. The ISM Band at 2.45 GHz with a bandwidth of 83 MHz is approved in most countries around the world. Nowadays most SAW-Sensor applications operate on this frequency, and also the industrial standard for RF-ICs move towards the 2,45 GHz frequency.

The pulsed RF read-signal has a widely spread si-

shaped frequency-characteristic. For example the small RF-pulse of 100 ns length, used in our application to interrogate the sensors, has a bandwidth of 10 MHz. Longer pulse-widths with a smaller bandwidth would decrease the resolution and require a longer delay line. Only the 2.45 GHz ISM band is capable to support the RF-pulse.

A further advantage of the high operating frequency is that the transmitting antenna, which is directly placed on the sensors on the patient's chest, can be miniaturized. Unfortunately, the acoustic attenuation on the substrate is higher at 2.45 GHz resulting in a decreased readout distance. Furthermore, other RF-technologies such as WLAN and Bluetooth are sharing the same frequency-band. Therefore, means for distinguishing the sensor signal from interfering signals are necessary.

#### IV. RESULTS

The resolution of the system is critical because of the extremely low voltages of the ECG and other biopotential signal sources. Also high transmission path loss makes an improvement of the signal-to-noise (SNR) necessary. In order to increase the system sensitivity the phase modulation of the sensor-response is evaluated primarily, because a higher signal to noise ratios can be achieved. This requires accurate matching of the resonant circuit to the driving frequency of the SAW-device.

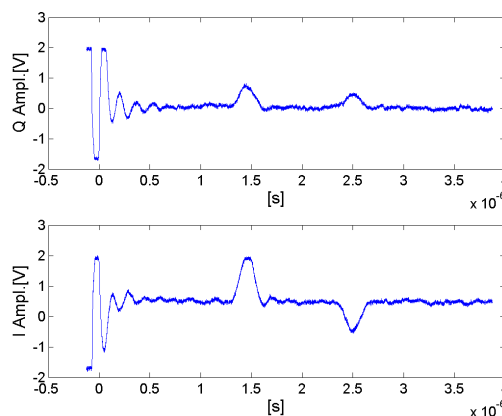
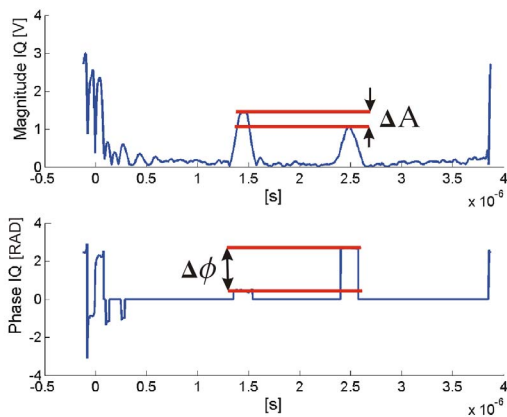

**Figure 5 In-phase and quadrature Signal of a single SAW-sensor measurement.**

This is achieved by a careful RF-design of the receiving path printed circuit board (PCB) layout and component matching. Furthermore, the SNR can be increased by successive calculation of the mean average of series of measurements. Due to the fact, that a single measurement takes only about 5 $\mu$ s and the desired measurement interval in ECG monitoring is 1ms at

minimum, multiple measurements can be made without degrading the ECG sample rate. These improvements however, will increase power consumption. Further study on this issue will help us to balance power consumption and good SNR.

Figure 5 shows the measured in-phase (I) and quadrature (Q) components after applying the IQ-demodulation on the response of a single sensor. The demodulator is a homodyne i.e. Zero-IF type with an integrated low noise amplifier (LNA) and adjustable low pass filter. All settings such as amplification, filter parameter and local oscillator frequency can be readily adjusted by a digital link from the DSP. The main advantage of the homodyne receiver architecture is its small size. An image rejection filter like in a classic heterodyne transceiver architecture is not necessary, thus reducing the dimension of the RF-part.



**Figure 6 Computed phase and amplitude information of the quadrature signals.**

The disadvantages of a Zero-IF receivers are self-mixing due to local oscillator leakage to the antenna which causes drift in DC offset and flicker noise which degrade the dynamic range of the receiver chain. Figure 5 shows the DC component of the baseband signal and some RF-noise induced from outside sources into the signal pass. Both components can be suppressed with a simple band-pass filter. The pass band of the filter has been chosen so that no significant information is filtered out. The cut off frequencies are 500 kHz and 10 MHz. A sample frequency of 40 MHz is therefore sufficient. The filtered signal is sampled by a two channel AD-Converter and recorded by the DSP. Amplitude and phase information can now be computed by the DSP as shown in Figure 6.

The current consumption of the whole RF-part is, as stated earlier, proportional to the amount of successive

interrogations for one ECG measurement. Between the interrogation cycles all RF-components and the controlling DSP switch a standby-mode, thus reducing the overall current consumption to less than 100  $\mu$ A. In the active phase current consumption adds up to 140 mA. With active/standby ratio of 1 to 4 power consumption can therefore be approximated to be less than 30 mA. Together with the electronic used for analysis and storage of the measured ECG data the overall current consumption should be less than 50mA, enabling a life-time of over 48h with a standard rechargeable battery.

## V. CONCLUSION

A first working prototype of the interrogation unit for ECG recording has been realised and the first measurements are promising, although not all requirements are met so far. The final RF-part of the interrogation unit have to fit into an existing ECG recording unit with only slight changes of the electrical interfaces. Through the use of BGA and multilayer techniques the dimension of the existing RF-part will be shrunk to fulfill this demand. Current consumption is, as compared to other wireless interrogation units, already very low. Improvements in software design, e.g. expanding the standby time, will allow a further drop of this value.

## VI. ACKNOWLEDGMENT

The authors would like to thank Philips Semiconductors for manufacturing the MOS-capacitors, R. Thomas and G. Scholl of EPCOS AG for the support in designing and simulation of the SAW-prototype, and the German Federal Ministry of Education and Research (BMBF) for financing the project.

## REFERENCES

- [1] A. Karilainen, Passive, Wireless ECG-Sensor Based on Impedance Loaded SAW-Transponders, 2004, Technische Universität Hamburg-Harburg.
- [2] K. Finkeneller, RFID-Handbuch, 2002, Carl Hanser Verlag München.