

# A Proof-of-concept demonstrator for Cognitive Radio

Marnix Heskamp, Fokke Hoeksema, Roel Schiphorst and Kees Slump  
University of Twente, Faculty of EEMCS,  
Signals and Systems Group (SaS),  
P.O. box 217 - 7500 AE Enschede - The Netherlands  
Phone: +31 53 489 2673 Fax: +31 53 489 1060  
E-mail: m.heskamp@utwente.nl

*Abstract*— The Adaptive Ad-hoc Free Band Wireless Communications (AAF) project is researching the possibility of using Software Defined Radio for wireless networks that needs to operate in an unknown or even hostile radio environment. Each node in the network needs to be cognitive of nearby transceivers in order to prevent radio frequency interference from and to other users and to survive jamming. So, in our system each node scans the radio spectrum to see which bands are free, so that these bands can be used for communication by the AAF network. The target application of our system is in a disaster relief wireless network. Since the chance of occurrence of a major emergency is very low, it will be very economical if the communication network of the rescue team can find free spectrum when it is needed, instead of reserving a fixed portion of the spectrum. In this paper we present a concept of a physical layer architecture of the scanning system of an AAF network node, and we will elaborate on the question of how it can be evaluated with of the shelf hardware.

*Keywords*— Cognitive Radio, Software Defined Radio, Spectrum estimation

## I. INTRODUCTION

The usage of the electromagnetic spectrum for telecommunication and broadcasting is regulated by government organizations like the Federal Communication Commission (FCC) in the US, and Agentschap Telecom (AT) in the Netherlands. Users are only allowed to use a some fixed narrow band of spectrum for which they obtained a license. For traditional analog radio systems, this rigid way of assigning the spectrum was necessary, and not too restrictive since bandwidths were not very large. Today this way of allocating the spectrum has led to the situation that according to the bandplan [1] there is almost no free spectrum available, but at the same time most of this allocated spectrum is not actually used most of the time.

For modern radio systems the necessity of a private piece of bandwidth is decreasing since modern digital modulation systems more and more are able

to adapt to a changing radio environment. A good example is frequency hopping (Bluetooth) in which multiple radio systems can share the same bandwidth at the same time. Frequency hopping is an example of spread spectrum. Other examples are Code division multiple access (CDMA) and Orthogonal frequency-division multiplexing (OFDM). An other modulation technique for which the traditional spectrum allocation paradigm is less appropriate is ultra wide band (UWB), since in this type of systems the signal power is spread over such a large bandwidth that it fades into the noise floor of conventional receivers.

Frequency hopping and UWB are examples of techniques that can use the spectrum of a primary user without causing unacceptable interference to this primary user. An important limitation of these systems is that they do not actually ensure that they do not interfere since they are ignorant about neighboring radio systems. Therefore the FCC has coined a new paradigm, which is called ‘Cognitive Radio’ [2], which means that a transmitting device first measures what is going on in the ether, then adapts its transmitter parameters to appropriate values based on those measurements, and then starts to send.

## II. THE AAF-PROJECT

In the Adaptive Ad-hoc Free Band Wireless Communications (AAF) project we want to research the possibilities of cognitive radio for mobile wireless networks used by rescue workers in emergency situations. The AAF project is part of the Freeband Communication Programme, which aims at the generation of public knowledge in advanced telecommunications.

The project consist of two tracks. The first track develops cognitive radio routing protocols, higher layer protocols and applications, based on the assumption that in the forthcoming years the physical and data link layer are able to support them. The second track is doing research on the physical- and data link layer. The goal of this second track research is finding out

whether cognitive radio is a pragmatic concept or just another hype. In order to be persuasive we think it is best to take a practical approach by building a demonstrator. We want to demonstrate that we can send and receive bits with a certain data rate, while we try to jam the signal. We also want to find out if we can avoid interference to a narrow band signal from a traditional transceiver system.

### III. SPECTRUM SCANNING ARCHITECTURE

Figure 1 shows an overview of the scanning system.

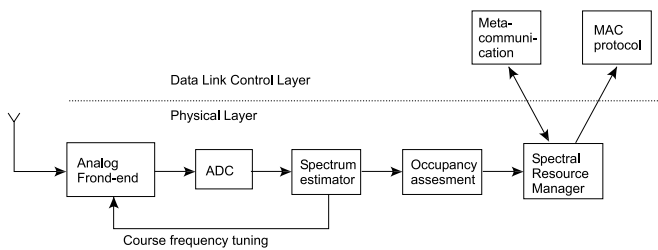

Fig. 1. Overview of scanning system of an AAF wireless network node

The spectral resource manager maintains a map of the time-frequency plane so that it can tell the MAC-protocol which frequencies can be used for communication. This map is based on bandplan knowledge, scanning history, input from other network nodes via some sort of meta-communication channel, and new output from occupancy assessment unit. The spectral occupancy unit is responsible for interpreting the measured power spectrum and making a decision whether a band is occupied or free.

The spectrum estimation itself is done with a combination of two well known methods. We use an FFT to obtain a fine grained spectrum over a medium sized frequency span. But since the FFT method costs a lot of power, both computationally and in the ADC, we can not use it to scan larger spans. Therefore we may need to combine it with a coarse grained band-selection that is done by adjusting the front-end oscillator in a frequency hopping manner.

#### A. The antenna

One of the most important, and easily overlooked, aspects of designing a radio system is the antenna. The main constraints of the antenna in this project are its size and form-factor, since it must be used on a handheld terminal that has to be used by a rescue worker. Since we plan to use the lower UHF-bands,

the antenna will have an intrinsic size of some decimeters. On those dimensions it seems likely that our only practical option is a simple whip antenna.

On the other hand the antenna must be sensitive enough, in a worst case scenario, to detect weak signals from a remote transmitter, meant for a primary user which is optimized to listen for that particular channel.

That it is not impossible to receive relative large bandwidths with a simple antenna can be seen if we look at Digital Audio Broadcasting (DAB). DAB uses UHF band III (174-240 MHz) that is traditionally used for television. There exist DAB car-radio's and portable DAB radio's that integrate the antenna in the headphone wire.

The AAF system also needs to be able to transmit over a frequency span that is much larger than the span of traditional portable transceiver systems. This may cause complications in the power amplifier due to reflections at the antenna. It is beyond the scope of the AAF project to do extensive research on antennas and analog front-ends. We do, however, need to some more study to get some feeling for what is possible.

#### B. The analog front-end

The analog front-end of the scanning system has different requirements than the front-end of a normal receiver. One requirement is that we can detect fairly weak primary user signal, but on the other hand we do not need to reconstruct the signal; we only need to detect its presents.

The main decision that must be made for the front-end is whether we use one single down-conversion stage, which results in the zero-IF architecture, or multiple stages, which results in the superheterodyne architecture.

The zero-IF architecture, as depicted in figure 2, is conceptually the most elegant solution, and would be at first sight the best option. There are, however, some important drawbacks. First, all selectivity must be provided by one single filter at baseband. Since we expect a large dynamic range this filter must be quite steep. Moreover, all components before this filter must support the full frequency span. Other disadvantages are Flicker noise, self mixing, I/Q-imbalance [3].

For this reason most receivers, and almost all spectrum analyzers, use the superheterodyne architecture. In a superheterodyne receiver the signal is first mixed to a fixed intermediate frequency (IF), and then passed trough a channel selection filter. Now the signal can be amplified much more efficient since a lot of

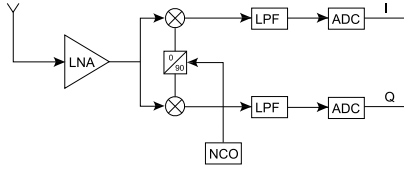

Fig. 2. Zero-IF architecture

out of band signal power is removed. After the first IF stage, other IF stages or a final complex mixing stage that converts the signal to baseband, can follow.

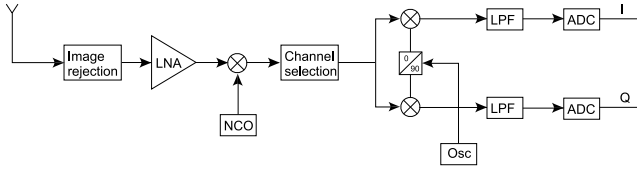

Fig. 3. Superheterodyne architecture

A third option that looks promising is the digital-IF architecture, that is similar to the superheterodyne architecture, except the final mixing step is performed by the ADC by means of under-sampling. This requires an ADC that has an analog bandwidth that is much larger than its digital bandwidth and sampling rate, like the AD6600 from Analog Devices [4].

### C. The analog to digital converter

The analog to digital converter (ADC) is a significant bottleneck of every digital radio system, since it inherently distorts the signals. For a given converter technology (ADC design is beyond the scope of the project) this distortion can only be made less at the cost of more power consumption. For our purpose we can divide the ADC distortion in three components: sampling, clipping and quantization. For a given power consumption requirement we can not minimize these components independently, so a trade-off must be made. Since we do not need to reconstruct the signal in the scanning system, this trade-off may be different than for the receiver.

Clipping will causes spurious frequency components at seemingly random frequencies. Attenuating the signal reduces clipping but at the same time brings the signal closer to the noise floor. We can tolerate some spurious frequencies as long as they not lead to false detections. A typical ADC has a voltage range from 2 Volt peak-peak and an impedance of 1 k $\Omega$ . If we assume we can clip the signal above 4 times the RMS

voltage this leads to a maximum ADC input power level of

$$P_{max} = 0.25^2/1000 = -12 \text{ dBm} \quad (1)$$

Quantization will add quantization noise to the signal, which has a uniform frequency and amplitude distribution if the quantization is not too coarse, and an RMS voltage of

$$V_{noise} = \frac{\Delta V}{\sqrt{12}} \quad (2)$$

in which the quantization step size  $\Delta V = V_{pp} \cdot 2^{-bits}$ . If our ADC has 14 bits the average quantization noise power is  $-89 \text{ dBm}$ , so the effective dynamic range is about  $77 \text{ dB}$ .

In order to prevent aliasing the ADC in each quadrature channel must sample at a rate equal or higher than the signal bandwidth. Since the fall-off of the channel selection filter is finite, some octaves of over-sampling is needed.

Over-sampling has the additional advantage that the quantization noise floor reduces in the power density spectrum, since the same quantization noise power is now spread over a larger bandwidth (sigma delta principle) [5]. So if we sample twice as fast, the quantization noise floor drops 3 dB in the power density spectrum, which gives one half bit of extra effective resolution. To what extent this principle is applicable for our spectrum scanning system is an issue for further research. The power consumption is also affected by this trade-off since the power consumption of an ADC is given by

$$P = \frac{1}{FoM} f_s \cdot 2^{bits} \quad (3)$$

in which FoM is a figure of merit that, for current day ADC is about 1600 GHz/W, and approximately doubles every three year [6]. For the test-bed it seems a good idea to use a high power ADC with much more resolution and bandwidth than required in a real world application, since it is relatively easy to emulate a low power ADC by removing bits and samples afterwards.

## IV. THE COGNITIVE-RADIO VERIFICATION PLATFORM

In our group we have experience in building ‘proof-of-concept’ demonstrators, like a software implementation of a HiperLAN/2 receiver [7] that is designed in

such way that extra functionality can be added ‘nearly for free’. We intent to build a similar demonstrator for the AAF project. Functions that needs to be implemented are adaptive OFDM, frequency scanning and meta communication.

Figure 4 shows an overview of the verification platform we intent to build [8]. It consist of two standard PC’s with dual Opteron processors. To provide additional processing power an Altera Field Programmable Gate Array (FPGA) is used. This FPGA is mounted on a PCI-X board manufactured by PLDA.

One of the PC’s is configured as transmitter, and the other as receiver. Both contain a scanning system so that we can study distributed scanning approaches.

For the analog front-end we intend to use commercially available building blocks. The up-conversion can be performed by a vector signal generator. For the scanning front-end we maybe can use a modified television tuner [9].

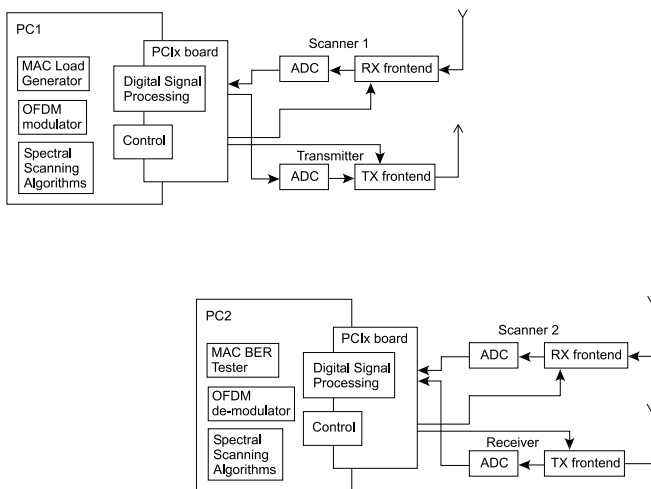

Fig. 4. Cognitive-radio verification platform

## V. CONCLUSIONS AND FURTHER WORK

In this paper we described an architecture for a spectrum scanner for a mobile wireless transceiver. Some problems arising in cognitive radio are discussed. We can conclude that the main bottlenecks in digital radio are in fact in the analog domain. The other main limitation is power consumption. Further study of these issues will be performed. We will also study existing radio spectrum occupancy data to establish the dynamic range and time-frequency resolution.

## ACKNOWLEDGMENT

This work is supported by the Dutch Ministry of Economic affairs BSIK funding project and it part of the FreeBand program.

## REFERENCES

- [1] Radiocommunications Agency The Netherlands) Dutch Ministry of Economic Affairs (Agentschap Telecom. National frequentieregister (national frequency register). <http://www.agentschap-telecom.nl/nfr/>, 2005.
- [2] Federal Communications Commission. Spectrum Policy Task Force. Rep. ET Docket no. 02-135, 2002. [http://hraunfoss.fcc.gov/edocs\\_public/attachmatch/D0C-228542A1.pdf](http://hraunfoss.fcc.gov/edocs_public/attachmatch/D0C-228542A1.pdf).
- [3] S. Haykin. *Communication Systems*. Wiley, third edition, 1994.
- [4] Brad Brannonn. Designing a Superheterodyne Receiver Using an IF Sampling Diversity Chipset. APPLICATION NOTE. Analog Devices.
- [5] J.H. Reed. *Software Radio, A Modern Approach to Radio Engineering*. Prentice Hall, 2002.
- [6] International Technology Roadmap for Semiconductors. Technical report. <http://public.itrs.net/>.
- [7] R. Schiphorst, F. Hoeksema, and V. Arkesteijn. The bluetooth-HiperLAN/2 SDR receiver project web site. Web site. [http://www.sas.el.utwente.nl/research/wireless-communication/software\\_defined\\_radio/](http://www.sas.el.utwente.nl/research/wireless-communication/software_defined_radio/).
- [8] J. Stermerdink et al. Initial Verification Platform Requirements and Architecture. AAF Deliverable D.20, 2005.
- [9] N.A. Moseley. Radio Resource Discovery for Ad-hoc Wireless Networking. Master’s thesis, EECSM department, University of Twente, 2004. EECSM-SAS 17-04.