

# A 60-GHz Push-Push Oscillator

Wei Liat Chan and John R. Long

**Abstract**— A push-push voltage-controlled oscillator (VCO) is designed in this paper. The VCO adds the differential output of a fundamental 30-GHz oscillator to give the second harmonic at 60 GHz. A buffer is present at the output to drive 50- $\Omega$  load. The VCO has a simulated tuning range from 55.4 GHz to 67 GHz (fundamentally from 27.7 GHz to 33.5 GHz). The VCO consumes 5 mA, and the buffer an additional 5.35 mA, all from a 1-V supply. The simulated output power driving 50  $\Omega$  varies from -6.4 dBm to -12.28 dBm across the entire tuning range.

**Index Terms**— push-push, oscillator, 60-GHz

## I. INTRODUCTION

Millimeter-wave circuit design for the 60-GHz band is gaining popularity [1-4]. The availability of 7 GHz bandwidth and the possibility of gigabit-per-second data transfer rate contribute much to the interest of this emerging band. Currently, circuits operating at such high frequencies have been realized in III-V semiconductor technology, which is prohibitively expensive. SiGe BiCMOS process, while cheaper, has shown great potential in meeting these challenges at this frequency with transistors of transit frequency over 200 GHz. Nevertheless, this technology is still more expensive than the traditional CMOS process. Today, the rapid scaling of CMOS technology, e.g. 65 nm and 90 nm, leads to the emergence of transistors with transit frequency over 200 GHz. There exists a possibility of designing circuits in CMOS to meet the challenges for this frequency band.

Fig. 1 shows a generic block diagram of a phase-locked loop (PLL). The primary function of the PLL is to provide a stable local oscillating signal for the mixers to perform both the up- and down-conversion operations. A crystal is often used to input a highly stable, low-frequency reference signal into the PLL. The phase comparator compares the phase difference between the reference signal and the output of the frequency divider (the voltage-controlled oscillator (VCO) drives the divider), and outputs a DC voltage to adjust the VCO till there is no phase difference. As the crystals only work in the mega-hertz range, a frequency divider is clearly needed for a PLL to function in the 60-GHz band.

The design of this VCO is non-trivial. Its power consumption must be kept minimal, and the phase noise must be low. The tuning range must also be wide, especially taking into account the process, voltage and temperature (PVT) variations. At millimeter-wave frequency, the power consumption of the VCO would be high because of the small

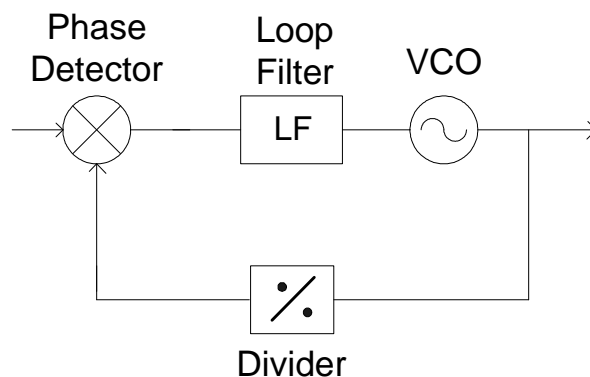

Fig. 1. Block diagram of a PLL.

power gain of the transistors. Also, the phase noise would be poor. Similarly, wide tuning range will be difficult to achieve.

In this paper, the design of a 60-GHz push-push VCO [5] in a 65-nm CMOS process is described. A push-push VCO adds the differential outputs of a fundamental VCO, i.e. 30 GHz, to give the second harmonic at 60 GHz. Ideally the second harmonic output power should be zero. However, as the two outputs of the differential VCO are not perfectly 180 degrees out of phase, there is a weak second harmonic presence. By amplifying the second harmonic, the output can drive a mixer, but in this case, a 50- $\Omega$  load. Also with this approach, it is easier to give a wider tuning range. The designed VCO has a simulated tuning range from 27.7 GHz to 33.5 GHz fundamentally, which means a tuning range from 55.5 GHz to 66.9 GHz at the second harmonic. Such wide tuning range is easily achieved. Also, this approach works under low supply voltage. From a 1-V supply, the VCO consumes 5 mA and the buffer an extra 5.35 mA. The output power driving 50- $\Omega$  varies from -6.4 dBm to -12.3 dBm.

## II. REALIZATION OF PUSH-PUSH VCO

The schematic of the push-push VCO is depicted in Fig. 2. Transistors - M1 and M2, inductor - L1 and L2, and varactor - C make up a typical VCO. The cross-coupled pair of M1 and M2 provides the negative resistance to undamp the resistive losses of a LC tank. The tank is formed by the inductor and the varactor. By varying the tuning voltage, the capacitance of the varactor can be changed and thus, changes the oscillation frequency. The differential outputs are taken from the drain



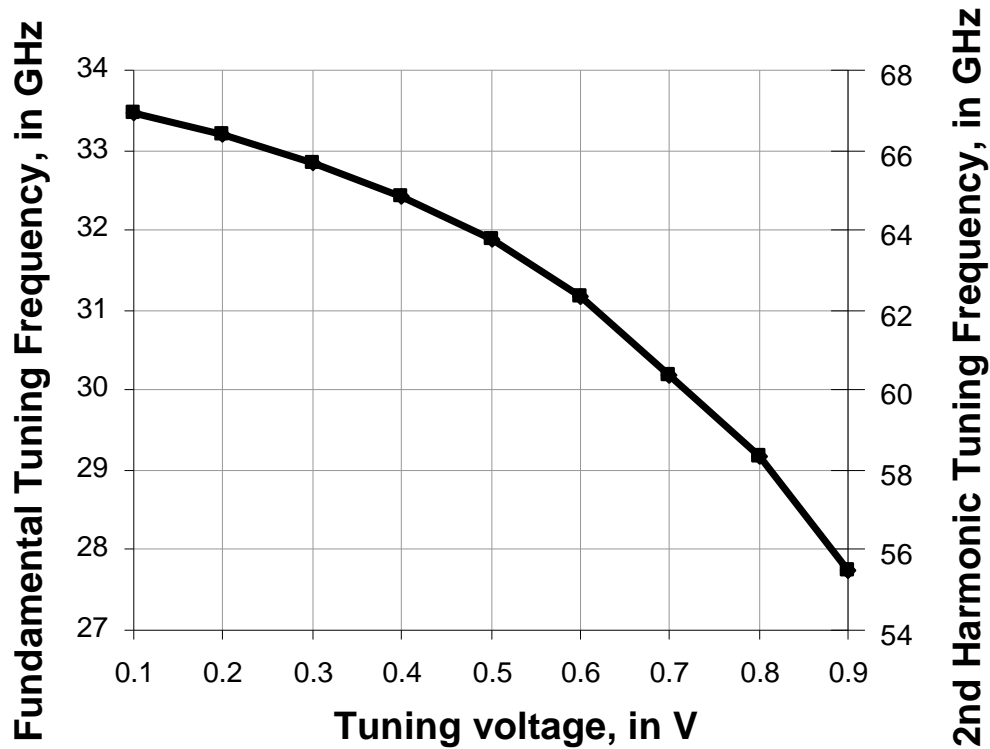

Fig. 3. Tuning curve of VCO, giving the fundamental oscillation frequency (left) and the second harmonic (right).

second harmonic output, which is at 60 GHz of a 30-GHz fundamental VCO, the strip line appears to be an open circuit, and thus, no signal is lost to the supply. Common-source amplifier of M3, with inductive load, amplifies the second harmonic to drive 50-Ω load.

### III. SIMULATION RESULTS

The push-push VCO is designed in a 65nm CMOS process. The VCO oscillates at 30 GHz fundamental, which gives the

second harmonic at 60 GHz. The designed VCO is given in Fig.2. From a 1-V supply, the VCO consumes 5 mW and the buffer an additional 5.35 mW. Fig. 3 shows the tuning curve of the VCO. From 0.1 V to 0.9 V, a broad tuning range from about 27.7 GHz to 33.5 GHz is achieved. Thus, the second harmonic varies from 55.4 GHz to 67 GHz, covering the entire 57 GHz to 64 GHz. Such a broad tuning range at 60 GHz will be difficult to achieve without using push-push VCO.

Fig. 4 shows the output power driving 50-Ω load, as the

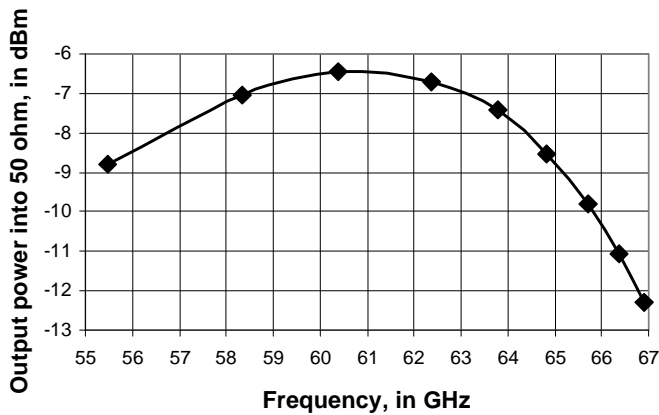

Fig. 4. Output power against frequency.

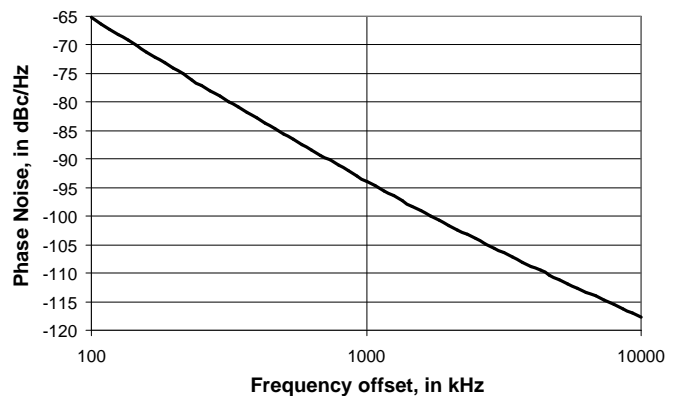

Fig. 5. Phase noise of the output of the push-push VCO.

VCO is tuned. The output power varies from about -6 dBm to -12.5 dBm, which should be sufficient to drive on-chip mixers. The phase noise of the second harmonic at default biasing is given in Fig. 5. Phase noise of about -95 dBc/Hz is achieved at 1-MHz offset from the carrier frequency.

#### IV. CONCLUSION

The design of a 60-GHz push-push VCO (fundamentally at 30 GHz) is presented. The differential outputs are added to give a second harmonic at 60 GHz, which is buffered to drive 50- $\Omega$  load. The VCO has a simulated tuning range from 55.4 GHz to 67 GHz or 27.7 GHz to 35.5 GHz fundamentally. From a 1-V supply, the VCO consumes 5 mA and the buffer an extra 5.35 mA.

#### ACKNOWLEDGEMENT

This work was supported by Freeband WiComm.

#### REFERENCES

- [1] B. Razavi, "A 60-GHz CMOS Receiver Front-End," *IEEE J. Solid-State Circuits*, vol. 41, no. 1, pp. 17-22, Jan. 2006.
- [2] B. A. Floyd, S. Reynolds, U. Pfeiffer, T. Beukema, J. Grzyb and C. Haymes, "A Silicon 60GHz Receiver and Transmitter Chipset for Broadband Communications," *ISSCC Dig. Tech. Papers*, pp. 184-185, Feb. 2006.
- [3] C. H. Doan, S. Emami, A. M. Niknejad and R. W. Brodersen, "Millimeter-Wave CMOS Design," *IEEE J. Solid-State Circuits*, vol. 40, no. 1, pp. 144-155, Jan. 2005.
- [4] B. A. Floyd, S. K. Reynolds, U. Pfeiffer, T. Zwick, T. Beukema and B. Gaucher, "SiGe Bipolar Transceiver Circuits Operating at 60 GHz," *IEEE J. Solid-State Circuits*, vol. 40, no. 1, pp. 156-167, Jan. 2005.
- [5] P.-C. Huang, M.-D. Tsai, G. D. Vendelin, H. Wang, C.-H. Chen and C.-S. Chang, "A Low-Power 114-GHz Push-Push CMOS VCO Using LC Source Degeneration," *IEEE J. Solid-State Circuits*, vol. 42, no. 6, pp. 1230-1239, June 2007.